

ITEM NO.	PART NUMBER	DESCRIPTION	QTY.
1	E-3R1-03	3rd GEAR INPUT SHAFT R1.556:1	1
2	E-3R1-04	4th GEAR INPUT SHAFT R1.273:1	1
3	E-3R1-05	5th GEAR INPUT SHAFT R1.043:1	1
4	E-3R1-07	2nd GEAR O/P SHAFT R1.938:1	1
5	E-3R1-08	3rd GEAR O/P SHAFT R1.556:1	1
6	E-3R1-09	4th GEAR O/P SHAFT R1.273:1	1
7	E-3R1-11	INPUT SHAFT INC. 1st,2nd & REV. GEARS	1
8	E-3R1-12	1st GEAR O/P SHAFT R3.000:1	1
9	E-3R1-16	5th GEAR O/P SHAFT R1.043:1	1
10	E-3R1-31	SPACER 5th GEAR O/P SHAFT	1
11	E-3R1-29	CROWN WHEEL R3.923:1	1
12	E-3R1-30	OUTPUT SHAFT R3.923:1	1
13	E-3R1-42	CROWN WHEEL R4.462:1	1
14	E-3R1-43	OUTPUT SHAFT R4.462:1	1
15	E-3R1-44	BEARING BUSH - 1st GEAR O/P SHAFT	1
16	E-3R1-63	THRUST WASHER - 1st GEAR O/P SHAFT	1
17	205	NEEDLE ROLLER - Ø3x23.8 LG	39

ALTERNATIVE

ALTERNATIVE

REQ'D IF STD. ROVER PART IS UNAVAILABLE

TITLE	ASSEMBLY
SCALE	1:1 U.O.S.
SHEET	1 OF 2
Drg. No.	E-3R1-01

FINISH	MACH	GRIND@C
LIMITS	FRACT	+ 1/64"
	DEC.	+ 0.005"
MATERIAL		
TREATMENT		
ISSUE 01	DATE	22.7.04
	DRAWN BY	J.P.D.
	LOTUS ELISE (P.G.1) 5 SPEED C.R.	
	Used In.	SYNCHROMESH GEAR KIT

IF IN DOUBT, ASK

SOLID WORKS

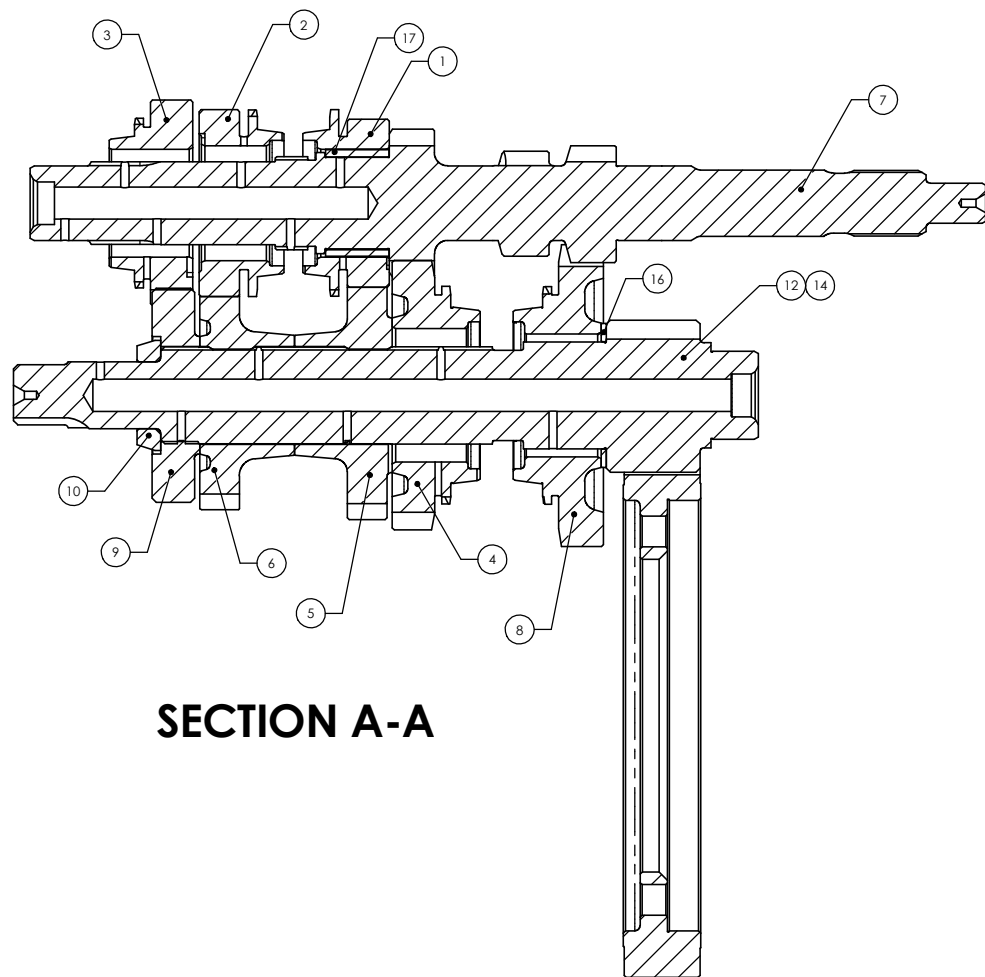

SECTION A-A

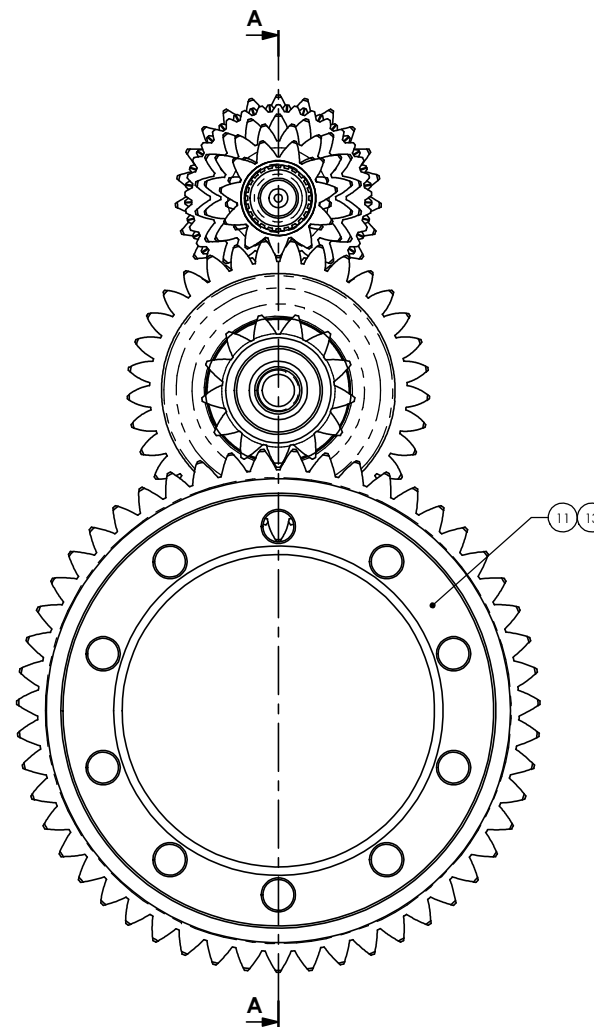

TITLE	ASSEMBLY
SCALE	1:1 U.O.S.
SHEET	2 OF 2
Drg. No.	E-3R1-01

FINISH	MACH	GRIND@G
LIMITS	FRACT	+ 1/64"
	DEC.	+ 0.005"
MATERIAL		
TREATMENT		
ISSUE 01	DATE	22.7.04
	DRAWN BY	J.P.D
	LOTUS ELISE (P.G.1)	5 SPEED C.R.
	Used In.	SYNCHROMESH GEAR KIT